

P. HAGEDORN and S. OTTERBEIN (*)

On the control of variable length tethered satellites with attitude-orbit coupling (**)

A GIORGIO SESTINI per il suo 70° compleanno

1. - Introduction

Several proposed future space missions involve large flexible systems and in particular also tethered satellites with tether length up to several hundred or even several thousand kilometers (see [2] to [5]). It is envisaged, for instance, to « hang a satellite down » from the orbiting Spacelab on tethers up to 100 km long. For such extreme tether lengths the usually negligible Attitude-Orbit-Coupling may become important, in particular during the operation of tether deployment or retraction.

The motion of two equal mass satellites connected by a tether of variable length has been studied previously during the deployment phase by Stuiver and Bainum [10]. More recently also cable-connected bodies in space have been discussed [1]_{1,2}.

The libration of extensible dumbbell satellites was studied by Paul [6] and the boom forces of librating satellites were examined in [7], [8]. In [9]₁ Stuiver discussed the attitude control of a two-body satellite system by arbitrary generalized torques. In a different paper [9]₂ the same author treated the three body problem with an additional « controlforce » between two of the bodies and showed that Lagrange-type configurations are possible. The relation between this latter problem and the dumbbell satellite is obvious.

(*) Indirizzo: Institut für Mechanik II, Technische Hochschule Darmstadt, Hochschulstrasse I, 6100 Darmstadt, Germany.

(**) Ricevuto: 5-II-1979.

The question of controllability of attitude and orbit by means of the variable tether length of a tethered satellite system however, apparently seems to have been neglected so far. The problem presents some interesting features due to the fact, that a first integral exists, which involves the variables tether length.

In what follows, the equations of planar motion of two equal mass satellites connected by a massless tether of variable length and moving in an inverse square force field are discussed. It is shown that the system is indeed completely controllable in a subspace of the state space defined by the constant moment of momentum, at least in the neighborhood of the « spoke » equilibria. It turns out that due to the particular form of the equations in the present case, the treatment of the problem in Hamiltonian form is far more convenient than the Lagrangean formulation.

It may therefore be possible to use the varying tether length of tethered satellites as a control for attitude and also for orbit parameters. A long time ago Beletskii [3] showed in an example that the periodic variation of the length of a dumbbell satellite may indeed be used to increase the orbit radius if the dumbbell axis is assumed to be perpendicular to the orbital plane. In this case however the tether would be under compression and moreover the attitude is unstable, so that this example does not seem to represent a practical situation. On the other hand, the question of controllability of the dumbbell satellites near the spoke equilibrium may be of some practical interest.

2. - Equation of motion

Consider a dumbbell or tethered satellite with two equal point masses and tether length $2z$ moving in the plane in an inverse square force field. Its

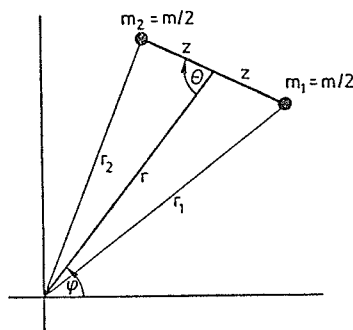

Fig. 1
(System geometry)

Lagrangian is

$$(1) \quad L = \frac{m}{2} [\dot{r}^2 + r^2 \dot{\varphi}^2 + \dot{z}^2 + z^2 (\dot{\varphi} - \dot{\theta})^2] + \frac{m}{2} \mu \left(\frac{1}{r_1} + \frac{1}{r_2} \right),$$

with

$$r_1^2 = r^2 + z^2 + 2zr \cos \theta, \quad r_2^2 = r^2 + z^2 - 2rz \cos \theta,$$

where the variables m, r, z, φ, θ are defined in Fig. 1 and μ is the constant of the gravitational field. The equations of motion in Lagrangean form are

$$(2)_1 \quad \ddot{r} = r\dot{\varphi}^2 - \frac{1}{2} \left[r \left(\frac{\mu}{r_1^3} + \frac{\mu}{r_2^3} \right) + z \cos \theta \left(\frac{\mu}{r_1^3} - \frac{\mu}{r_2^3} \right) \right],$$

$$(2)_2 \quad \ddot{\varphi} = -2 \frac{\dot{r}}{r} \dot{\varphi} + \frac{1}{2} \frac{\dot{z}}{r} \sin \theta \left(\frac{\mu}{r_1^3} - \frac{\mu}{r_2^3} \right),$$

$$(2)_3 \quad \ddot{\theta} = -2 \frac{\dot{r}}{r} \dot{\theta} + 2 \frac{\dot{z}}{z} (\dot{\varphi} - \dot{\theta}) + \frac{1}{2} \left(\frac{\dot{z}}{r} + \frac{\dot{r}}{z} \right) \sin \theta \left(\frac{\mu}{r_1^3} - \frac{\mu}{r_2^3} \right),$$

with the integral of moment of momentum (per unit mass) about the center of attraction

$$(3) \quad D = r^2 \dot{\varphi} + z^2 (\dot{\varphi} - \dot{\theta}).$$

It what follows we will also need the equations of motion in Hamiltonian form. The generalized momenta corresponding to r, φ, θ are

$$(4) \quad p_r = \frac{\partial L}{\partial \dot{r}} = m\dot{r}, \quad p_\varphi = \frac{\partial L}{\partial \dot{\varphi}} = m[r^2 \dot{\varphi} + z^2 (\dot{\varphi} - \dot{\theta})],$$

$$p_\theta = \frac{\partial L}{\partial \dot{\theta}} = -mz^2 (\dot{\varphi} - \dot{\theta}),$$

and the Hamiltonian is

$$(5) \quad H = \frac{1}{2m} [p_r^2 + \frac{1}{r^2} (p_\varphi + p_\theta)^2 + \frac{1}{z^2} p_\theta^2] - \frac{m}{2} \dot{z}^2 - \frac{m}{2} \left(\frac{\mu}{r_1} + \frac{\mu}{r_2} \right).$$

The variable z is not transformed since we wish to control the state variables

by means of the control functions $z(t)$ or $\dot{z}(t)$. Hamiltons equations turn out as

$$(6)_{1,2,3} \quad \dot{r} = \frac{1}{m} p_r, \quad \dot{\varphi} = \frac{1}{m} \frac{1}{r^2} (p_\varphi + p_\theta), \quad \dot{\theta} = \frac{1}{m} \left(\frac{1}{r^2} p_\varphi + \left(\frac{1}{r^2} + \frac{1}{z^2} \right) p_\theta \right),$$

$$(6)_4 \quad \dot{p}_r = \frac{1}{m} \frac{1}{r^3} (p_\varphi + p_\theta)^2 - \frac{m}{2} \left(r \left(\frac{\mu}{r_1^3} + \frac{\mu}{r_2^3} \right) + z \cos \theta \left(\frac{\mu}{r_1^3} - \frac{\mu}{r_2^3} \right) \right),$$

$$(6)_{5,6} \quad \dot{p}_\varphi = 0, \quad \dot{p}_\theta = \frac{m}{2} r z \sin \theta \left(\frac{\mu}{r_1^3} - \frac{\mu}{r_2^3} \right).$$

It is obvious that the first integral (3) is now given by $p_\varphi = \text{const.}$ since the variable φ is ignorable. Since the system has one ignorable variable φ also Routh's form of the equations of motion may be used, it does however not present any advantages for our purpose.

The integration of the equations of motion reduces to a fourth order differential system and two additional quadratures. This is obvious from (6) because p_φ is constant and $p(t)$ can be evaluated after the solution of the other equations. In Lagrange's equations (2) the variable $\dot{\varphi}$ can be eliminated by means of (3) and the right hand sides of the differential equations are then functions of $r, \theta, \dot{r}, \dot{\theta}$ only (besides the control variables), so that the first and the third equations in (2) can be solved as a system, $\varphi(t)$ being obtained subsequently by quadratures.

It should be noted that the right hand sides of (2) contain z and \dot{z} whereas the right hand sides of (6) depend only on z , although \dot{z} appears explicitly in H . Of course this can only happen because the equations (4), which define the transformation from the generalized velocities to the momenta, contain z explicitly.

Equations (6) permit to see directly what happens at a point of discontinuity of $z(t)$, where z jumps from z_1 to z_2 . It is obvious that $r, \varphi, \theta, p_r, p_\varphi, p_\theta$ remain continuous but $\dot{\theta}, \dot{p}_r$ and \dot{p}_θ also jump. In the Lagrangean variables we then have $r, \varphi, \theta, \dot{r}, \dot{\varphi}$ continuous with a jump only in $\dot{\theta}$. This conclusion could not be reached immediately from (2) since these equations are valid in this form only at the points where $z(t)$ is differentiable.

3. - General considerations about the system's controllability

Of course the system can be controllable only in a state space restricted by the first integral (3) or $p_\varphi = \text{const.}$ Let us first consider the equations in Lagrangean form (2), with z as control variable and with the additional dif-

ferential equation $\dot{z} = u$. The variable z is then a state variable and the following question arises.

Question I. Given two states $(r_1, \varphi_1, \theta_1, \dot{r}_1, \dot{\varphi}_1, \dot{\theta}_1, z_1)$ and $(r_2, \varphi_2, \theta_2, \dot{r}_2, \dot{\varphi}_2, \dot{\theta}_2, z_2)$, which correspond to the same value of the first integral (3), is there a control function $\dot{z}(t)$ which drives the system from state 1 to state 2?

This and the other questions on controllability will not be answered in all generality but only for the dumbbell satellite sufficiently close to a «spoke» equilibrium position, since in this case the equations linearized about this equilibrium position is given by

$$(17) \quad r(t) = r_0, \quad \varphi(t) = \omega t, \quad \theta(t) = 0, \quad z(t) = z_0,$$

with $\omega^2 = \mu/r_0^3(1 + \chi_0^2)/(1 - \chi_0^2)^2$, $\chi_0 = z_0/r_0$. In general χ_0 is small, so that the first two terms of the series $\omega^2 = \mu/r_0^3(1 + 3\chi_0^2 + \dots)$ give a very good approximation.

The equations (2) are now linearized in

$$\bar{x}_1 = r - r_0, \quad \bar{x}_2 = \varphi - \omega t, \quad \bar{x}_3 = \theta, \quad \bar{x}_4 = \dot{r}, \quad \bar{x}_5 = \dot{\varphi} - \omega, \quad \bar{x}_6 = \dot{\theta}, \quad \bar{x}_7 = z - z_0, \quad u = \dot{z},$$

and assume the form

$$(8) \quad \dot{\bar{x}}_i = \sum_{j=1}^6 a_{ij} \bar{x}_j + b_i \bar{x}_7 + c_i u \quad (i = 1, 2, \dots, 6), \quad \dot{\bar{x}}_7 = u.$$

If only solutions with the same moment of momentum about the center of attraction as the «spoke» equilibrium are considered, the first integral for the linearized equations gives

$$(9) \quad 2r_0 \omega \bar{x}_1 + (r_0^2 + z_0^2) \bar{x}_5 - z_0^2 \bar{x}_6 + 2z_0 \omega \bar{x}_7 = 0.$$

This equation can be used to eliminate \bar{x}_1 , \bar{x}_5 or \bar{x}_6 from (8). If \bar{x}_6 is eliminated we obtain

$$(10) \quad \dot{\bar{x}}_k = \sum_{s=1}^5 \tilde{a}_{ks} \bar{x}_s + b_k \bar{x}_7 + c_k u \quad (k = 1, 2, \dots, 5), \quad \dot{\bar{x}}_7 = u,$$

and \bar{x}_6 is given by (9). The total controllability of system (8) can now be examined by means of any of the available criteria. If for example Kalman's criterion is used and (10) is written in matrix form as

$$(11) \quad \dot{\mathbf{x}}(t) = \mathbf{A}\mathbf{x}(t) + \mathbf{B}u(t),$$

then the rank of $(\mathbf{B}, \mathbf{AB}, \dots, \mathbf{A}^{n-1}\mathbf{B})$ has to be calculated with $n = 6$. If (11) has full rank Question I can be answered affirmatively if the given states are close to the « spoke » equilibria.

As we shall see below, the use of Hamilton's equations leads to a similar equation but with $n = 5$. Since the difference of one order in the system may simplify the calculations appreciably, we will not attempt to compute the rank of the controllability matrix of (10) but we prefer to formulate the problem via Hamilton's equations.

Considering the control problem defined by (6), the new question arises

Question II. Given two states $(r_1, \varphi_1, \theta_1, p_{r_1}, p_{\theta_1})$ and $(r_2, \varphi_2, \theta_2, p_{r_2}, p_{\theta_2})$ with the same value of p_φ is there a control function $z(t)$ which drives the system from state 1 to state 2?

The linearization of (5) in $\bar{y}_1 = r - r_0$, $\bar{y}_2 = \varphi - \omega t$, $\bar{y}_3 = \theta$, $\bar{y}_4 = p_r$, $\bar{y}_5 = p_\theta + mz_0^2\omega$ and $u = z - z_0$ gives

$$(12) \quad \bar{y}_i = \sum_{j=1}^5 d_{ij} \bar{y}_j + e_i u \quad (i = 1, 2, \dots, 5),$$

and Kalman's or other criteria can be used to study the controllability of (12). If (12) is completely controllable Question II is to be answered affirmatively. The two different questions are obviously due to the fact that in the first case z is a state variable, in the second case a control variable.

4. - Application of Kalman's criterion

It is convenient to define the dimensionless variables

$$(13) \quad \begin{aligned} \bar{r} &= \frac{1}{r_0} (r - r_0), & \bar{p}_r &= \frac{p_r}{mr_0\omega}, & \bar{\varphi} &= \varphi - \omega t, \\ \bar{p}_\theta &= \frac{1}{mz_0^2\omega} (p_\theta + mz_0^2\omega), & \bar{\theta} &= \theta, & \bar{z} &= \frac{1}{z_0} (z - z_0), \end{aligned}$$

and to write the linearized equations of motion in these new variables

$$(14) \quad \begin{aligned} \bar{r}' &= \bar{p}_r, & \bar{\varphi}' &= -2\bar{r} + \chi_0^2 \bar{p}_\theta, & \bar{\theta}' &= -2\bar{r} + (1 + \chi_0^2) \bar{p}_\theta + 2\bar{z}, \\ \bar{p}_r' &= (2\alpha_0 \eta_0^2 - 3) \bar{r} + 2\chi_0^2 \bar{p}_\theta - 2\chi_0^2 \beta_0 \eta_0^2 \bar{z}, & \bar{p}_\theta' &= -\beta_0 \eta_0^2 \bar{\theta}, \end{aligned}$$

where a prime indicates differentiation with respect to the new dimensionless time $\tau = \omega t$ and

$$(15) \quad \eta_0^2 = \frac{(1 - \chi_0^2)^2}{(1 + \chi_0^2)} = \frac{\mu/r_0^3}{\omega^2}, \quad \alpha_0 = \frac{1 + 3\chi_0^2}{(1 - \chi_0^2)^3}, \quad \beta_0 = \frac{3 + \chi_0^2}{(1 - \chi_0^2)^3}.$$

In the matrix form (11) we now have

$$(16) \quad \mathbf{A} = \begin{bmatrix} 0 & 0 & 0 & 1 & 0 \\ -2 & 0 & 0 & 0 & \chi_0^2 \\ -2 & 0 & 0 & 0 & 1 + \chi_0^2 \\ 2\alpha_0\eta_0^2 - 3 & 0 & 0 & 0 & 2\chi_0^2 \\ 0 & 0 & -\beta_0\eta_0^2 & 0 & 0 \end{bmatrix},$$

$$(17) \quad \mathbf{B}^T = 2(0, 0, 1, -\chi_0^2\beta_0\eta_0^2, 0)$$

and a somewhat tedious calculation gives

$$(18) \quad \det(\mathbf{B}, \mathbf{A}\mathbf{B}, \dots, \mathbf{A}^4\mathbf{B}) = -2^9 \left(\frac{3 + \chi_0^2}{1 - \chi_0^2}\right)^4 \left(\frac{\chi_0^2}{1 - \chi_0^2}\right)^3 (\chi_0^2 - 9).$$

It is now easily verified that (18) is positive for $0 < \chi_0 < 1$ so that (14) is completely controllable for realistic values of χ_0 . The answer to Question II is therefore « yes ».

It is therefore possible to use the variable tether length to control the linearized system in the $r, \varphi, \theta, p_r, p_\theta$ space. We are however more interested in the answer to Question I since we wish to know if for instance a suitable function $z(t)$ drives the system from one « spoke » equilibrium $r_0, \varphi_0, \theta = 0, \dot{r} = 0, \dot{\varphi}_0 = \omega, \dot{\theta} = 0, z_0$ to another $r_0 + \Delta r, \varphi_0 + \Delta\varphi, \theta = 0, \dot{r} = 0, \dot{\varphi} = \omega + \Delta\omega, \dot{\theta} = 0, z = z_0 + \Delta z$.

The relation between z and r for different spoke equilibria with the same moment of momentum is given by the first integral (3) with $\dot{\theta} = 0$ and $\dot{\varphi}^2 = \omega^2 = (\mu/r_0^3)(1 + \chi_0^2)/(1 - \chi_0^2)^2$, and is also shown in Fig. 2. Of course only the first quadrant in Fig. 2 is significant, because we suppose r and z positive. In Fig. 2 the same scale is used on the r/r_{\max} and on the z/r_{\max} axis, so that the lower curve in the first quadrant corresponds to spoke equilibria in which the tether goes through the center of attraction and this curve can also be disregarded for practical purposes. Of course the z/r_{\max} axis which is also part of the diagram is of no practical importance. In most applications

$\chi = z/r$ will not be too large, so that the equilibrium corresponds to a point on the curve in the first quadrant close to $(0, 1)$.

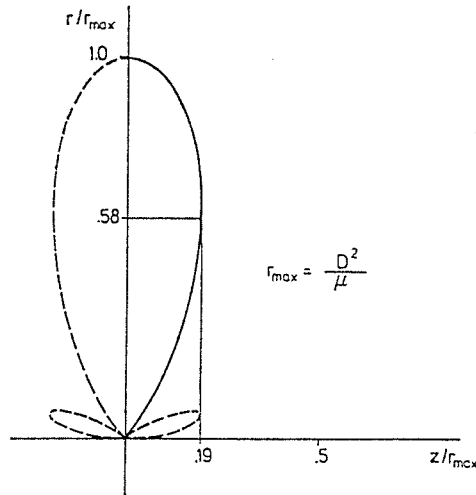

Fig. 2

(Values of r and z for different spoke equilibria with the same moment of momentum).

It is easily shown, that (14) is not only controllable in \bar{z} but also in $\bar{z}' = u$ if this equation is added to (14). In the Kalman criterion this means that the order is increased by one and \bar{A} , \bar{B} are substituted respectively by

$$(19) \quad \bar{A} = \begin{bmatrix} \bar{A} & \bar{B} \\ 0 & 0 \end{bmatrix} \quad \text{and} \quad \bar{B} = \begin{pmatrix} 0 \\ \vdots \\ 1 \end{pmatrix}.$$

A simple computation shows that

$$(20) \quad 1 + \text{rank}(\bar{B}, \bar{A}\bar{B}, \dots, \bar{A}^{n-1}\bar{B}) = \text{rank}(\bar{B}, \bar{A}\bar{B}, \dots, \bar{A}^n\bar{B}),$$

if \bar{B} is a vector as in our case, so that (14) is also controllable in \bar{z}' , with \bar{z} as a state variable.

Question I can now be answered: given $(r_1, \varphi_1, \theta_1, \dot{r}_1, \dot{\varphi}_1, \dot{\theta}_1, z_1)$ and $(r_2, \varphi_2, \theta_2, \dot{r}_2, \dot{\varphi}_2, \dot{\theta}_2, z_2)$ one can easily calculate $(\bar{r}_1, \bar{\varphi}_1, \bar{\theta}_1, \bar{p}_{r_1}, \bar{p}_{\varphi_1}, \bar{z}_1)$, $(\bar{r}_2, \bar{\varphi}_2, \bar{\theta}_2, \bar{p}_{r_2}, \bar{p}_{\varphi_2}, \bar{z}_2)$. Since (14) is completely controllable in \bar{z}' , we know that functions $\bar{z}'(\tau)$ exist which drive the systems from state 1 to state 2, so that the answer to Question I is also « yes ».

If Routh's equations were used we would have obtained a system of differential equations which would not have contained $\dot{\varphi}$ and φ . Since this system would be of lower order also the examination of the controllability would have been easier. It would however not have been known without additional considerations whether also the variables φ and $\dot{\varphi}$ were controllable or not. The controllability of these variables is however also of interest in a number of cases.

5. - Reformulation of the linearized equations

The system (14) can easily be transformed into one single differential equation of fourth order in any of the state variables. If we choose \bar{r} as the dependent variable for this fourth order equation we obtain, after some intermediate calculations

$$(21) \quad \bar{r}^{IV} + 2a\bar{r}'' + b\bar{r} = -2c(d\bar{z} + \bar{z}''),$$

with

$$(22) \quad a = \frac{2 + \chi_0^2}{1 + \chi_0^2}, \quad b = \frac{1}{1 - \chi_0^2} \frac{3 + \chi_0^2}{1 - \chi_0^4} (1 - 10\chi_0^2 + \chi_0^4),$$

$$c = \chi_0^2 \frac{3 + \chi_0^2}{1 - \chi_0^4}, \quad d = \frac{5 - \chi_0^2}{1 - \chi_0^2}.$$

The initial values not only of \bar{r} and \bar{r}' but also of \bar{r}'' and \bar{r}''' of course have to be found. If we start from a spoke equilibrium it is obvious that \bar{r} and \bar{r}' both vanish. From (14) with $\bar{\theta}(0) = 0$, $\bar{\varphi}(0) = 0$ we then can obtain

$$(23) \quad \bar{r}''(0) = -2\chi_0^2 \frac{3 + \chi_0^2}{1 - \chi_0^4} \bar{z}(0), \quad \bar{r}'''(0) = -2\chi_0^2 \frac{3 + \chi_0^2}{1 - \chi_0^4} \bar{z}'(0).$$

The solution to the differential equation (21) with these initial conditions can be written in the following form

$$(24) \quad \bar{r}(\tau) = -\frac{2c}{\mu_2^2 - \mu_1^2} \int_0^\tau \left(\frac{d - \mu_1^2}{\mu_1} \sin \mu_1(\tau - \eta) - \frac{d - \mu_2^2}{\mu_2} \sin \mu_2(\tau - \eta) \right) \bar{z}(\eta) d\eta,$$

where c , d are given in (22) and $\mu_{1,2}$ are given by

$$(25) \quad \mu_{1,2}^2 = \frac{1}{1 - \chi_0^4} \left((2 + \chi_0^2)(1 - \chi_0^2) \pm \sqrt{1 + 22\chi_0^2 + 33\chi_0^4 + 8\chi_0^6} \right),$$

as is shown in some more detail in the Appendix. By direct differentiation of (24) it can however also easily be checked that (24) is in fact a solution to (21).

With (24) the influence of a changing tether length on \bar{r} can be computed and a simple estimate can be found as follows. From (24) with

$$(26) \quad r(t) - r_0 = r_0 \bar{r}(\omega t), \quad \bar{z}(\eta) = \frac{1}{z_0} [z(\eta/\omega) - z_0],$$

we obtain

$$(27) \quad r(t) - r_0 = -\frac{1}{\chi_0} \frac{2c}{\mu_2^2 - \mu_1^2} \omega \int_0^t \left\{ \frac{d - \mu_1^2}{\mu_1} \sin \mu_1 \omega(t - s) - \frac{d - \mu_2^2}{\mu_2} \sin \mu_2 \omega(t - s) \right\} (z(s) - z_0) ds.$$

We therefore have

$$(28) \quad |r(t) - r_0| \leq \frac{\omega t}{\chi_0} \left(\left| \frac{2c}{\mu_2^2 - \mu_1^2} \right| \cdot \left(\left| \frac{d - \mu_1^2}{\mu_1} \right| + \left| \frac{d - \mu_2^2}{\mu_2} \right| \right) \max_{0 \leq s \leq t} |z(s) - z_0| \right)$$

and if we expand the terms on the right hand side of (25) in powers of χ_0 , we have for the initial terms of this expansion

$$(29) \quad \frac{2c}{\mu_2^2 - \mu_1^2} = 3\chi_0^2 + \dots, \quad \frac{d - \mu_1^2}{\mu_1} = 4 + \dots, \quad \frac{d - \mu_2^2}{\mu_2} = \frac{2}{3} \sqrt{3} + \dots$$

Using these expansions in (28) gives

$$(30) \quad |r(t) - r_0| \leq \chi_0 15,46 \max_{0 \leq s \leq t} |z(s) - z_0| \omega t + 0(\chi_0),$$

or

$$(31) \quad |r(T) - r_0| \leq 2\pi \chi_0 15,46 \max_{0 \leq s \leq T} |z(s) - z_0| + 0(\chi_0),$$

where T is the orbital period of the satellite. From (31) we see that during one orbital period the change in r will be at most of the order of $15\chi_0 \Delta z 2\pi$, where Δz is the maximum change of z during one period. This means that for all practical purposes the change in r during one orbital period will be very small.

6. - Conclusions

We have shown in this paper that the planar motion of a system of two equal mass tethered satellites in a central inverse square force field is completely controllable with respect to the tether length $2z$, in the subspace of the state space defined by the first integral of moment of momentum, in the neighborhood of a «spoke» equilibrium. Surprisingly not only the attitude but also the orbit and even the variables φ and $\dot{\varphi}$ can be controlled by z' . This means that possibly the tether length control can be used to correct small orbit disturbances, e.g. to drive the system from an orbit with small eccentricity back to the spoke equilibrium in a circular orbit.

As mentioned previously in the paper, Beletskii [3] gave an example in which he showed that periodic variations of the length of a dumbbell satellite could be used to increase the orbital radius indefinitely if the dumbbell axis is assumed to remain perpendicular to the orbital plane. This interesting example is apparently of no practical importance, as previously explained. In the present case however, in which the planar motion of the dumbbell is considered, no appreciable increase in r will be possible in general, maintaining the satellite close to a spoke equilibrium. This can be seen from Fig. 2, where the usual spoke equilibria are on the equilibrium curve and close to the point (0, 1). In this region reductions in z increase r , but of course never above $r = r_{\max}$. In the lower part of the curve of course an increase in z corresponds also to an increase in r . This part of the diagram is however probably also of little practical value, since here $\chi = z/r$ is very large.

In the last section of the paper an alternate solution was given to the control problem and a simple estimate for the change of r due to the changing z was given. It was shown that Δr remains always small and a most of the order of $15,46\chi_0 \Delta z 2\pi$ during one orbital period.

Summarizing it can be said that the tether length control may possibly be used to make the spoke equilibrium asymptotically stable and to correct extremely small deviations in the orbital parameters, but certainly not for larger orbit correction.

Appendix

We wish to obtain a closed form solution of

$$(A.1) \quad \bar{r}^{IV} + 2a\bar{r}'' + b\bar{r} = -2c(d\bar{z} + \bar{z}'')$$

with

$$(A.2) \quad \bar{r}(0) = 0, \quad \bar{r}'(0) = 0, \quad \bar{r}''(0) = -2c\bar{z}(0), \quad \bar{r}'''(0) = -2c\bar{z}'(0)$$

for arbitrary functions $\bar{z}(\tau)$. The general solution to the *homogeneous* equation is given by

$$(A.3) \quad R_H(\tau) = A_1 \cos \mu_1 \tau + A_2 \sin \mu_1 \tau + A_3 \cos \mu_2 \tau + A_4 \sin \mu_2 \tau$$

and a particular solution to the inhomogeneous problem can be written as

$$(A.4) \quad R_p(\tau) = -2c \int_0^\tau R(\tau - \eta) [d\bar{z}(\eta) + \bar{z}''(\eta)] d\eta,$$

where $R(\tau)$ is a particular solution of the homogeneous problem with initial conditions

$$(A.5) \quad R(0) = 0, \quad R'(0) = 0, \quad R''(0) = 0, \quad R'''(0) = 1.$$

From (A.3) and (A.5) one obtains

$$(A.6) \quad R(\tau) = \frac{1}{\mu_2^2 - \mu_1^2} \left[\frac{1}{\mu_1} \sin \mu_1 \tau - \frac{1}{\mu_2} \sin \mu_2 \tau \right].$$

The solution $R_p(\tau)$ trivially satisfies the initial conditions $R_p(0) = 0$, $R_p'(0) = 0$, $R_p''(0) = 0$, $R_p'''(0) = 0$ so that for the solution $\bar{r}(\tau)$ of the inhomogeneous problem with the initial conditions given by (A.2) one obtains

$$(A.7) \quad \begin{aligned} \bar{r}(\tau) = R_H^0(\tau) + R_p(\tau) = & -\frac{2c}{\mu_2^2 - \mu_1^2} [\bar{z}(0)(\cos \mu_1 \tau - \cos \mu_2 \tau) \\ & + \bar{z}'(0) \left(\frac{1}{\mu_1} \sin \mu_1 \tau - \frac{1}{\mu_2} \sin \mu_2 \tau \right) \\ & + \int_0^\tau \left(\frac{1}{\mu_1} \sin \mu_1(\tau - \eta) - \frac{1}{\mu_2} \sin \mu_2(\tau - \eta) \right) (d\bar{z}(\eta) + \bar{z}''(\eta)) d\eta]. \end{aligned}$$

Integrating the term containing $\bar{z}''(\eta)$ by parts one finally gets

$$(A.8) \quad \bar{r}(\tau) = -\frac{2c}{\mu_2^2 - \mu_1^2} \int_0^\tau \left(\frac{d - \mu_1^2}{\mu_1} \sin \mu_1(\tau - \eta) - \frac{d - \mu_2^2}{\mu_2} \sin \mu_2(\tau - \eta) \right) z(\eta) d\eta,$$

which corresponds to (24).

References

- [1] P. M. BAINUM and K. S. EVANS: [\bullet]₁ *Three-dimensional motion and stability of two rotating cable-connected bodies*, J. Spacecraft **12** (1975), 242-250; [\bullet]₂ *The three-dimensional motion and stability of a rotating space station cable-counterweight configuration*, Final Report, NASA Grant NGR-09-011-053, Dept. of Mechanical Engineering, Howard University, Washington, D. C. (1974).
- [2] P. M. BAINUM, R. E. HARKNESS and W. STUIVER, *Attitude stability and damping of a tethered orbiting interferometer satellite system*, J. Astronaut. Sci. **19** (1972), 364-389.
- [3] V. V. BELETSKII, *Studies on the motion of cosmic bodies* (in russian), Nauka, Moscow 1972.
- [4] G. COLOMBO, E. M. GAPOSCHKIN, M. D. GROSSI and G. G. WEIFFENBACH, *The «Shyhook»: a shuttle-borne tool for low-orbital-attitude research*, Meccanica **10** (1975), 3-20.
- [5] W. FLURY and J. BOISSIERES, *Gravity field determination with a dumb-bell satellite*, ESOC, International note n. 193, August 1977.
- [6] B. PAUL, *Planar librations of an extensible dumb-bell satellite*, AIAA J. **1** (1963), 411-418.
- [7] I. SAEED and W. STUIVER, *Periodic boom forces in dumb-bell-type satellites moving in a circular orbit*, AIAA J. **12** (1974), 423-424.
- [8] S. C. SHARMA and W. STUIVER, *Boom forces in librating dumb-bell-type satellites*, AIAA J. **12** (1974), 425-426.
- [9] W. STUIVER: [\bullet]₁ *Dynamics and configuration control of two-body satellite systems*, J. Spacecraft and Rockets **11** (1974), 545-546; [\bullet]₂ *Lagrange configurations in space system dynamics*, J. Astronaut. Sci. **25** (1977), 91-106.
- [10] W. STUIVER and P. W. BAINUM, *A study of planar deployment control and libration damping of a tethered orbiting interferometer satellite*, J. Astronaut. Sci. **20** (1973), 321-346.

Abstract

Several proposed future space missions involve large flexible systems and in particular also tethered satellites with tether length up to several hundred or even several thousand kilometers (see [2] to [5]). It is envisaged, for instance, to «hang a satellite down» from the orbiting Spacelab on tethers up to 100 km long. For such extreme tether lengths the usually negligible Attitude-Orbit-Coupling may become important, in particular during the operation of tether deployment or reaction.

The motion of two equal mass satellites connected by a tether of variable length has been studied previously during the deployment phase by STUIVER and BAINUM [10]. More recently also cable-connected bodies in space have been discussed [1]_{1,2}.

The libration of extensible dumbbell satellites was studied by PAUL [6] and the boom forces of librating satellites were examined in [7] [8]. In [9]₁ STUIVER discussed the attitude control of a two-body satellite system by arbitrary generalized torques. In a different paper [9]₂ the same author treated the three body problem with an additional «control

force » between two of the bodies and showed that LAGRANGE-type configurations are possible. The relation between this latter problem and the dumbbell satellite is obvious.

The question of controllability of attitude and orbit by means of the variable tether length of a tethered satellite system however apparently seems to have been neglected so far. The problem presents some interesting features due to the fact, that a first integral exists, which involves the variable tether length.

In this paper, the equations of planar motion of two equal mass satellites connected by a massless tether of variable length and moving in an inverse square force field are discussed. It turns out that due to the particular form of the equations in the present case, the treatment of the problem in Hamiltonian form is far more convenient than the Lagrangian formulation.

It is shown that the planar motion of a system of two equal mass tethered satellites in a central inverse square force field is completely controllable with respect to the tether length $2z$, in the subspace of the state space defined by the first integral of moment of momentum, in the neighborhood of a «spoke» equilibrium. Surprisingly not only the attitude but also the orbit and even the variables φ and $\dot{\varphi}$ can be controlled by z ! This means that possibly the tether length control can be used to correct small orbit disturbances, e.g. to drive the system from an orbit with small eccentricity back to the spoke equilibrium in a circular orbit.

A long time ago, BELETSKII [3] gave an example in which he showed that periodic variations of the length of a dumbbell satellite could be used to increase the orbital radius indefinitely if the dumbbell axis is assumed to remain perpendicular to the orbital plane. This interesting example is apparently of no practical importance. In the present case however, in which the planar motion of the dumbbell is considered, it is shown that no appreciable increase in r will be possible in general, maintaining the satellite close to a spoke equilibrium.

In the last section of the paper an alternate solution is given to the control problem and a simple estimate for the change of r due to the changing z is given. It is shown that Δr remains always small and at most of the order of $15,46 \cdot 10^{-6} \Delta z \cdot 2\pi$ during one orbital period, with $z_0 = z_0/r_0$.

Summarizing it can be said that the tether length control may possibly be used to make the spoke equilibrium asymptotically stable and to correct extremely small deviations in the orbital parameters, but certainly not for large orbit corrections.

* * *